



**Active Travel &  
Health WG**

# Promoting Active Travel in COVID-19 Times

EUROPEAN MOBILITY WEEK: Campaigns to  
support zero-emission mobility solutions  
**MOMOB Webinar Series**



[www.polisnetwork.eu](http://www.polisnetwork.eu)

**15<sup>th</sup> September, 14:00 – 15:00**



# Context





# Unbalanced distribution of public space in cities – the need to reallocate space for people



**Car street:** Carriageway is devoted to motorised traffic, pedestrians crowded on pavement/sidewalks



**Expanded curb:** parking/traffic lane re-purposed as pedestrian space to provide physical spacing



**Emergency cycle track:** parking/traffic lane re-purposed as cycle track to absorb avoided transit trips



**Emergency cycle track and expanded curb:** Both measures help safely retain the vitality of dense areas



**Slow streets:** allow car access, but not through traffic. Priority given to pedestrians/cyclists and speeds are below 20km/h



**Open street:** entire street opened to cyclists/pedestrians but closed to all but emergency/essential car access

Systematica, Milan. Analysis of the suitability of pavements for maintaining social distancing.

Philippe Crist, International Transport Forum



# Opportunities

*Behaviour change*

*Experimentation*

*Affordability*







# POLIS Response to COVID-19 Outbreak

## DURING LOCKDOWN

Webpage: Cities taking action to [keep things moving](#)  
- [Useful resources on COVID-19 and mobility](#)

## POST-LOCKDOWN MOBILITY PLANNING

- [Post-lockdown Mobility Webinar Series](#)
- Technical Tailored meetings on specific topics

## FUTURE OUTLOOK

- Advocating for sustainable mobility: Letter: [European exit strategy must show strong support for sustainable urban mobility](#)
- Providing strategic guidance: [COVID-19 SUMP Practitioner Briefing](#)

# POLIS response: post-lockdown mobility

## *Post-lockdown mobility webinar series*

**17 thematic webinars in 2 months**

**Topics: parking, bikesharing, public transport...**

**Webinars looking at active travel:**

- Reallocation of space to promote active travel (x2)
- Walk and Bike to School
- Bikesharing: in cooperation with Cycling Industries

[www.polisnetwork.eu](http://www.polisnetwork.eu)



<https://www.polisnetwork.eu/news/post-lockdown-mobility-a-covid-19-webinar-series-for-polis-members/>

**POLIS**



# POLIS response: post-lockdown mobility

## Post-lockdown mobility webinar series

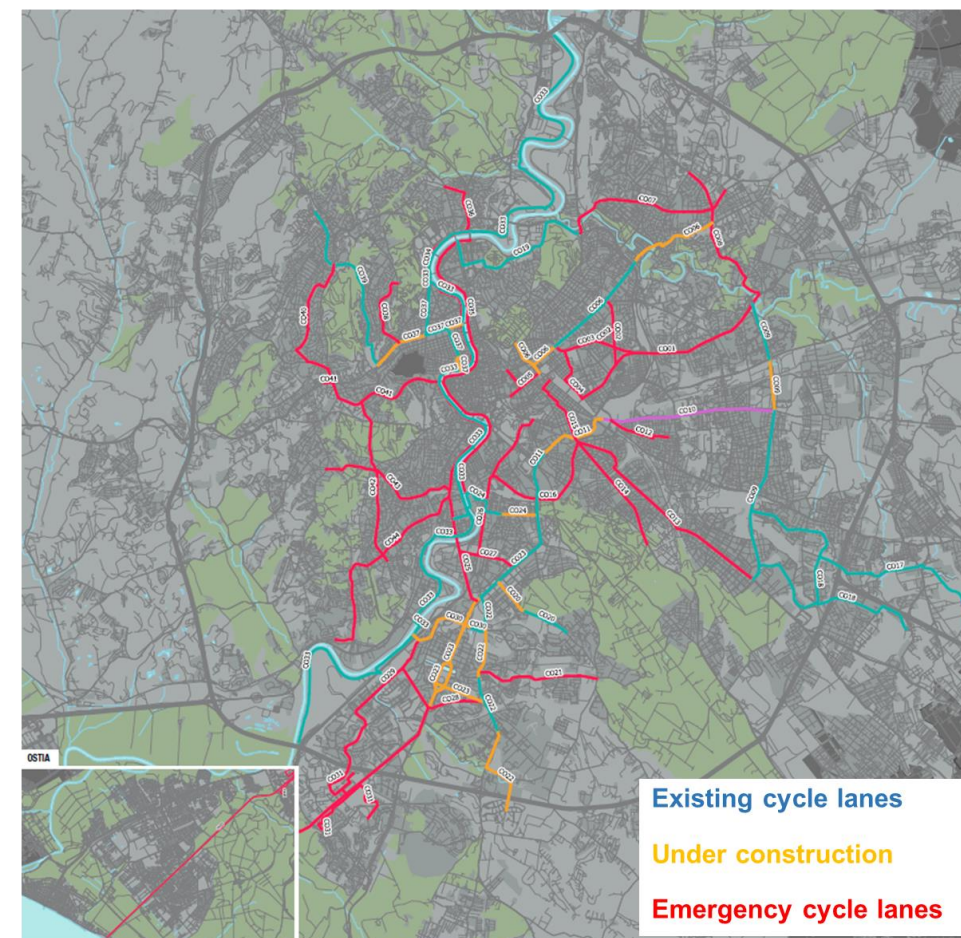
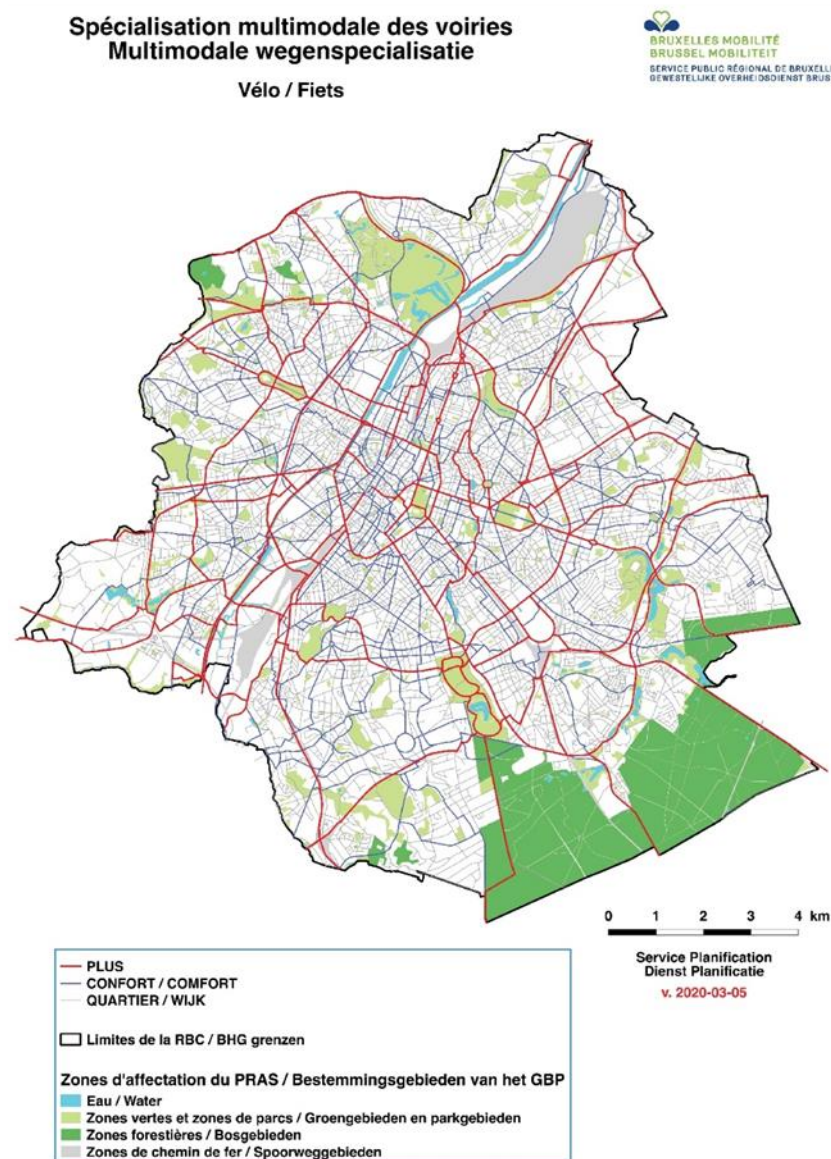

>> Rome

## RER-V TEMPORARY CYCLE PATHS

Map of the temporary cycle paths

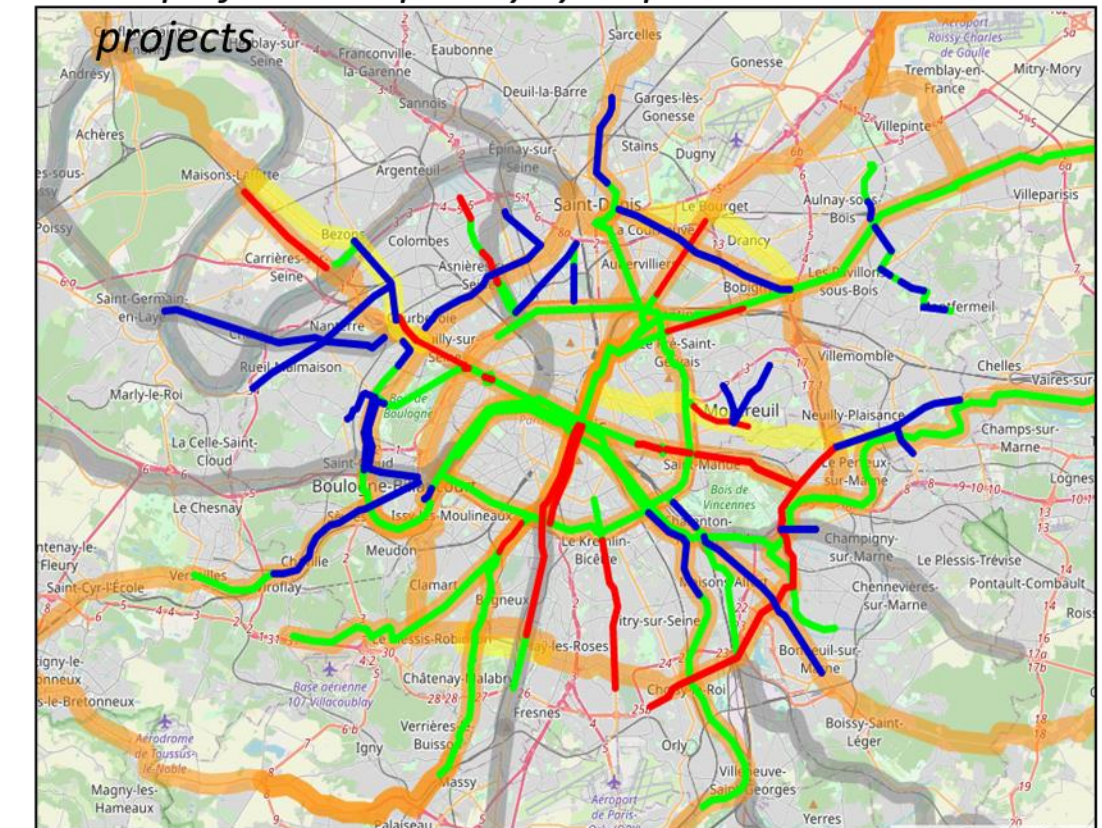

>> Ile de France

>> Brussels

[www.polisnetwork.eu](http://www.polisnetwork.eu)



# POLIS response: post-lockdown mobility

## Technical sessions: Physical infrastructure & materials

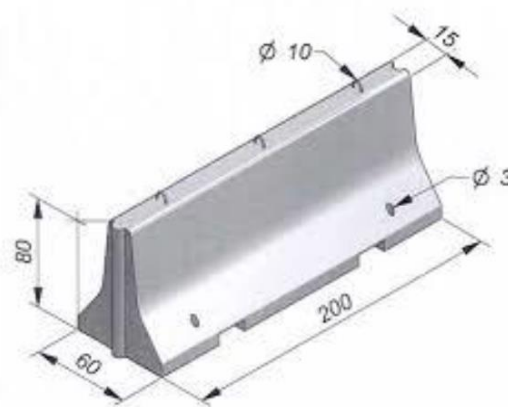

Technical session on Physical infrastructure & materials, organized by the Traffic and Efficiency WG



# Advocating for Active Travel

## POLIS

*Letter: European exit strategy must show strong support for sustainable urban mobility.*

## **New Paradigm for Safe City Streets**

## **EC GUIDANCE ON COVID-19 LOCKDOWN EXITING**

### Active travel

- Urban areas could consider **temporary enlargements of pavements** and **increased space for active mobility options**
- **Reducing speed limits** of vehicles in increased active mobility areas could be considered



# COVID-19 SUMP Practitioner Guide

- Direction on how to put the **EC guidance on COVID-19** lockdown exiting into practice
- **SUMP Practitioner Briefing** based on **good practices** from cities in Europe.
- The document is intended to be an inspirational and **practically useful document**.
- Future SUMP Topic guide: **lessons learned, consolidated recommendations** and other comprehensive material.



[COVID-19 SUMP Practitioner Briefing](#)



# COVID-19 SUMP Practitioner Guide

- Direction on how to put the **EC guidance on COVID-19** lockdown exiting into practice
- **SUMP Practitioner Briefing** based on **good practices** from cities in Europe.
- The document is intended to be an inspirational and **practically useful document**.
- Future SUMP Topic guide: **lessons learned, consolidated recommendations** and other comprehensive material.



[COVID-19 SUMP Practitioner Briefing](#)





**Active Travel &  
Health WG**

# Thank you!

**Maria Jose Rojo**

Project manager

Coordinator Active Travel & Health

**Polis Network**

**[mjrojo@polisnetwork.eu](mailto:mjrojo@polisnetwork.eu)**