

Paid parking zones in the capital city of Prague

Ing. Libor Šíma

Prague City Hall

Krakow – 15.9. 2016

- The first zones were launched

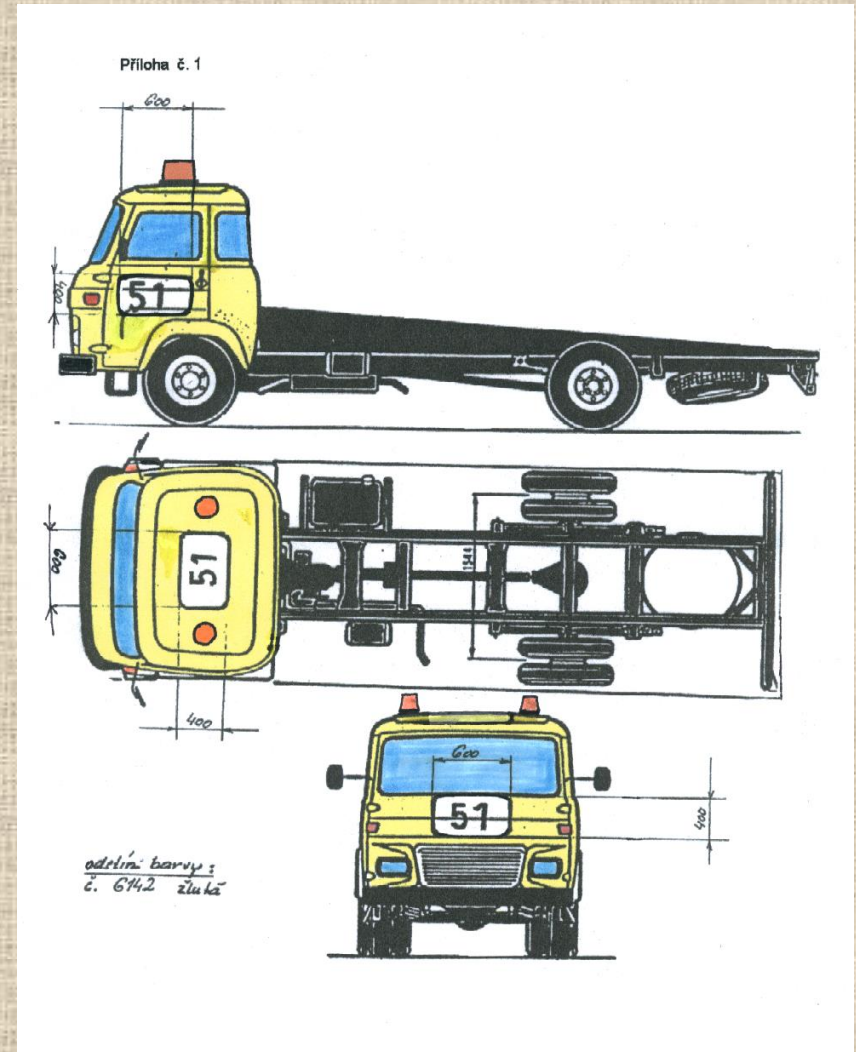

1996

- The right bank of the Prague

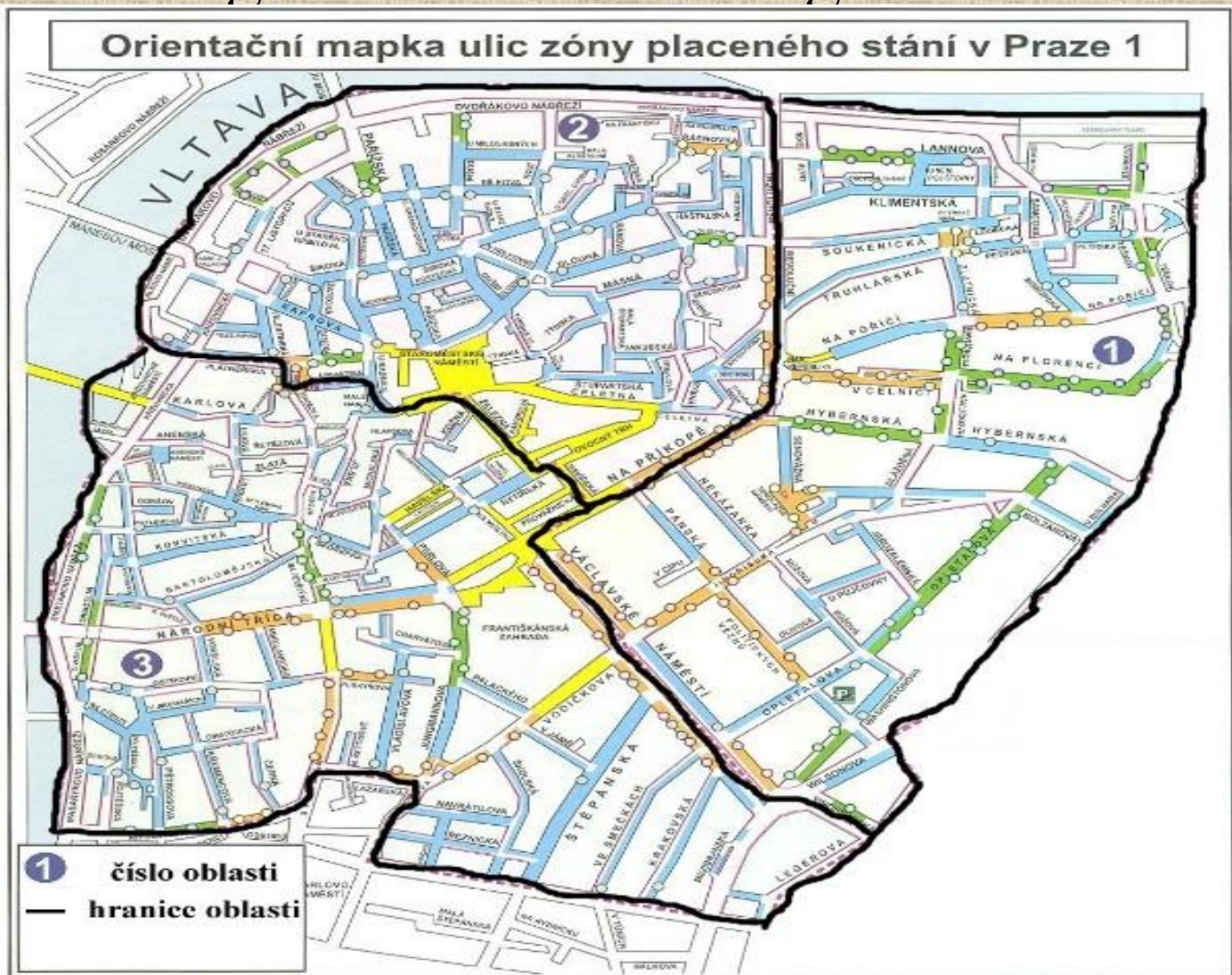

PRAHA
PRAHA
PRAHA
PRAHA

History 1979 - 2016

viz pokyny na zadní straně
see reverse side for instruction
siehe Hinweise auf der Rückseite

2 HODINY
2 HOURS
2 STUNDEN

PRAHA **PARKOVACÍ KARTA**
PRAHA **PARKING CARD**
PRAHA **PARKKARTE**



PLATÍ POUZE PRO MODROU ZÓNU
VALID ONLY IN BLUE ZONE
GILT NUR FÜR BLAUE ZONE

HODINA		HOUR		UHR	
0	1	2	3	4	5
6	7	8	9	10	11
12	13	14	15	16	17
18	19	20	21	22	23

MINUTA		MINUTE		MINUTE	
00	10	20	30	40	50

CENA / PRICE / PREIS 120 Kč

REKLAMA

MĚSÍC		MONTH		MONAT	
I	II	III	IV	V	VI
VII	VIII	IX	X	XI	XII

DEN		DAY		TAG			
1	2	3	4	5	6	7	8
9	10	11	12	13	14	15	16
17	18	19	20	21	22	23	24
25	26	27	28	29	30	31	



2007 (2008)

• Widening – Prague 2, 3, 7

Rozšíření zón placeného stání

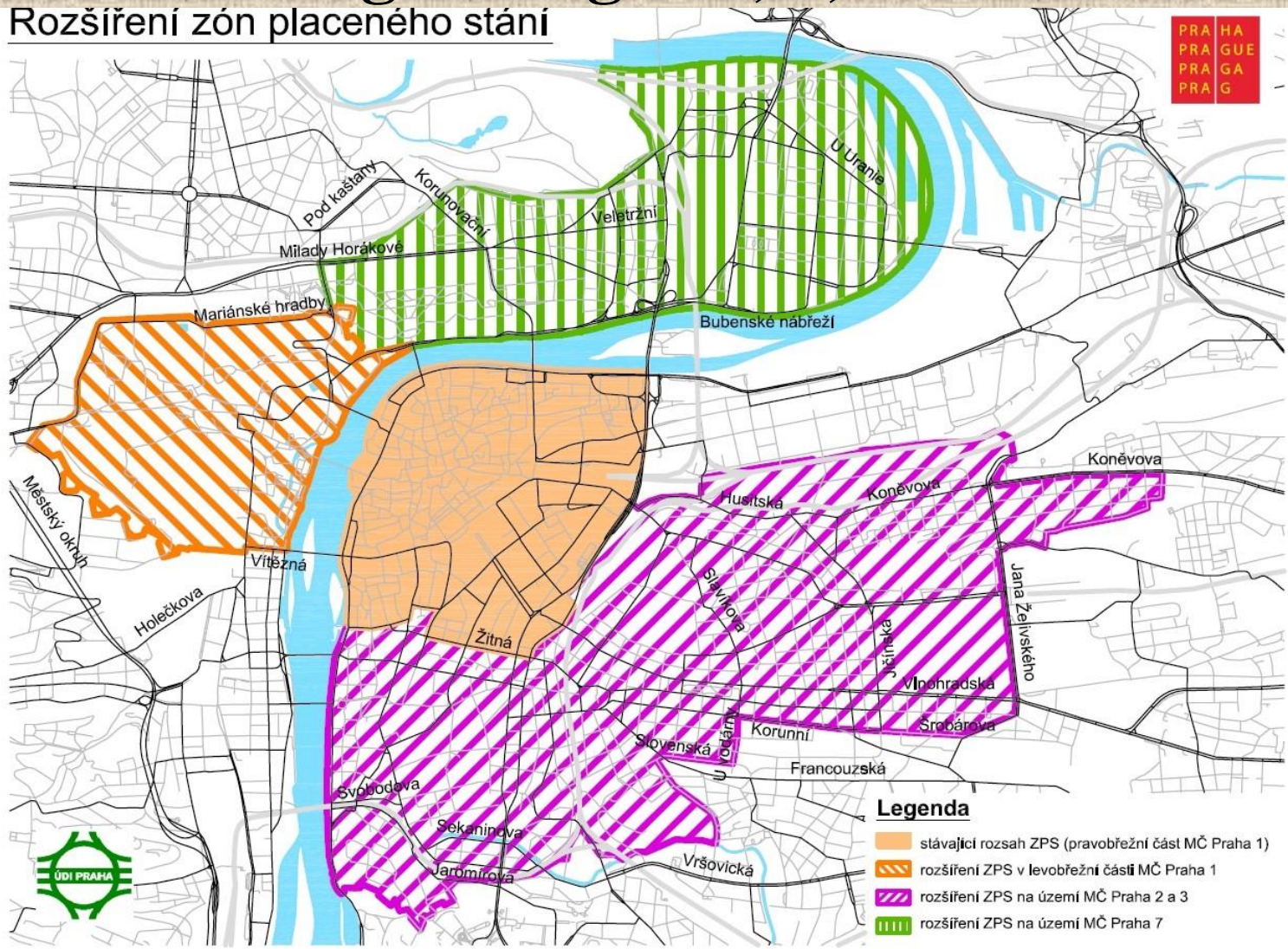

2011 – Traffic analyses

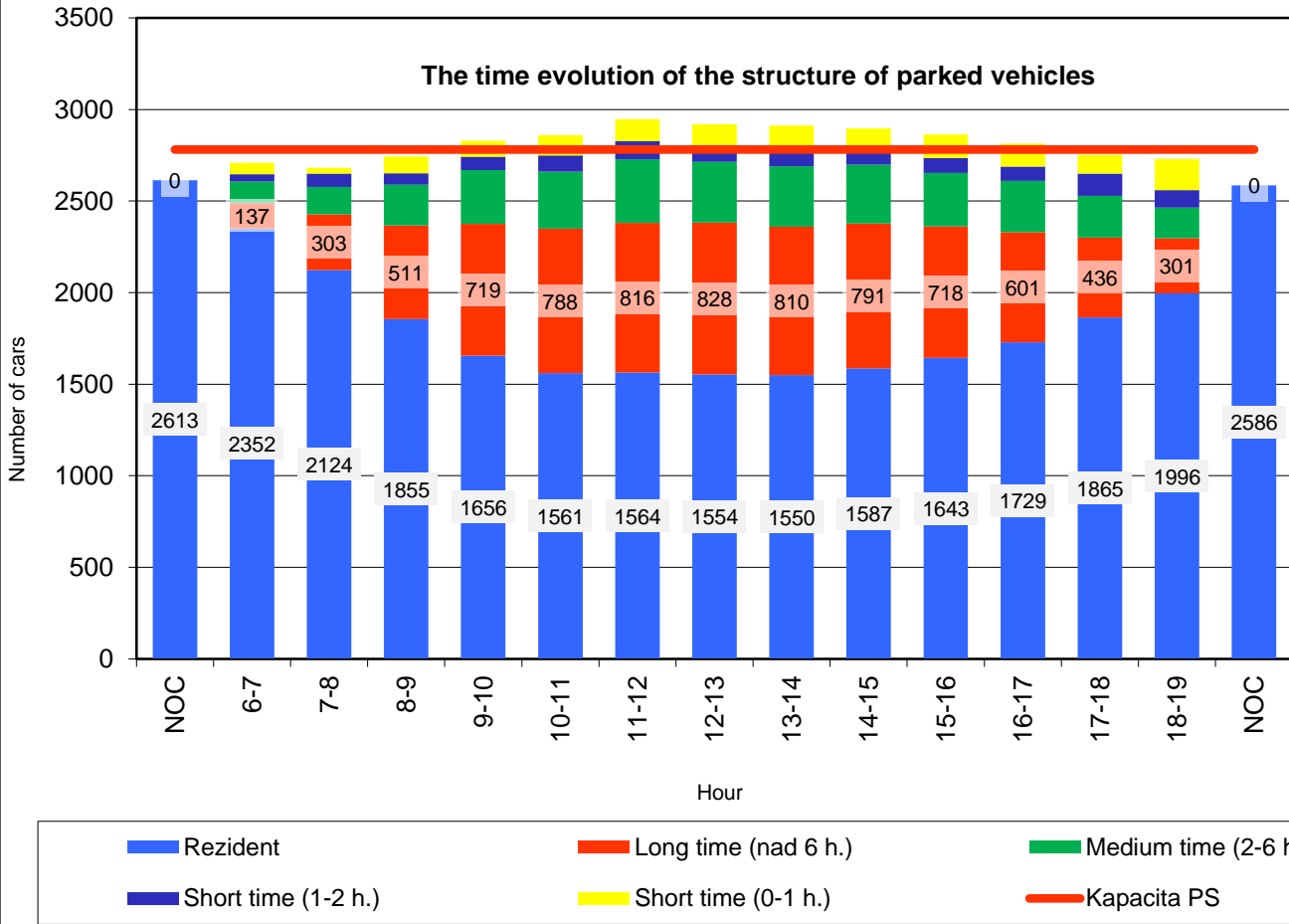

Passportisation
Demography
Traffic analyses
Availability
Rotation
Time structure
Reserves

Projects of parking organization 2014 - 2015

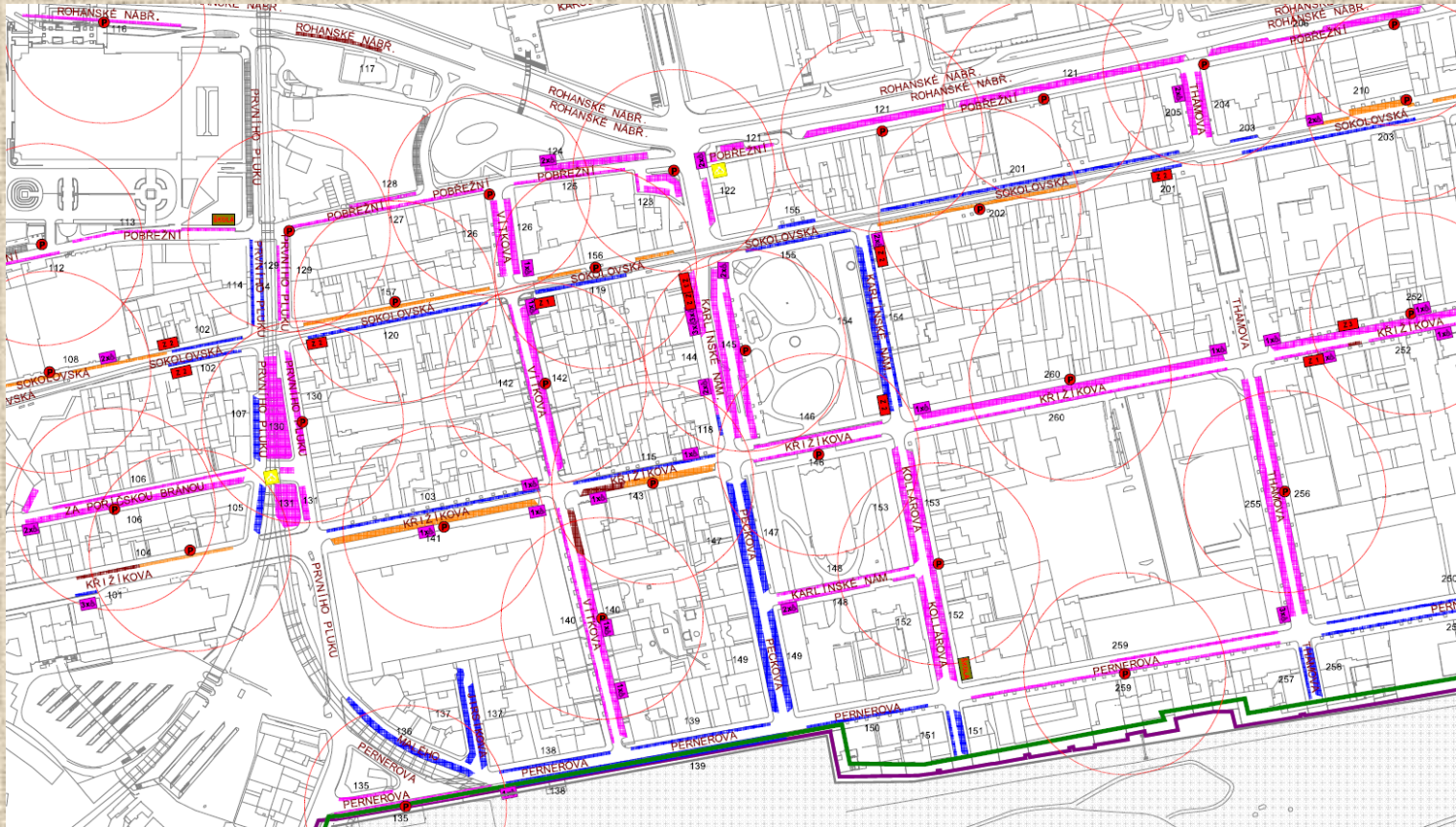

2016

Implementation projects
Traffic signs
Parking meters

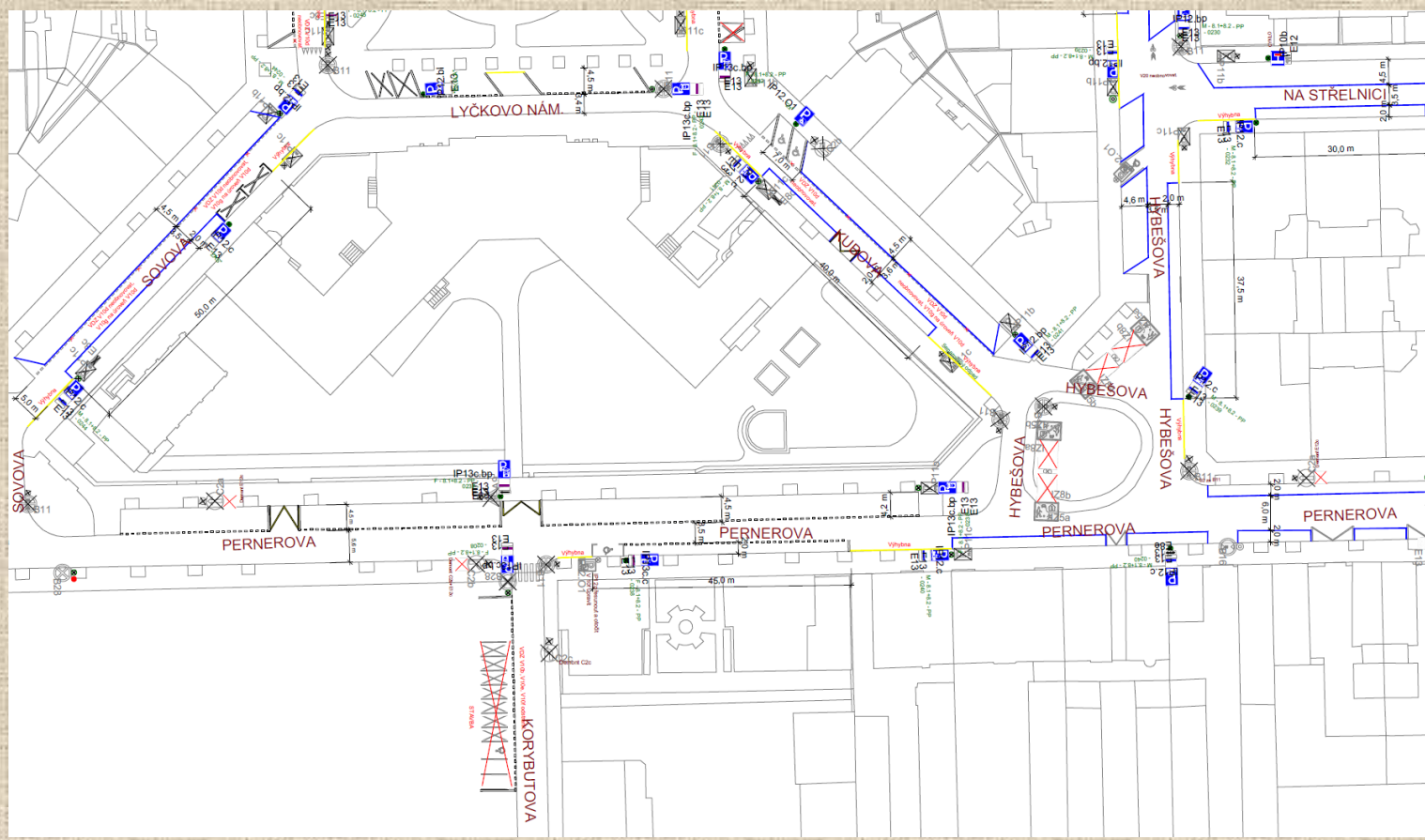

Colour symbols

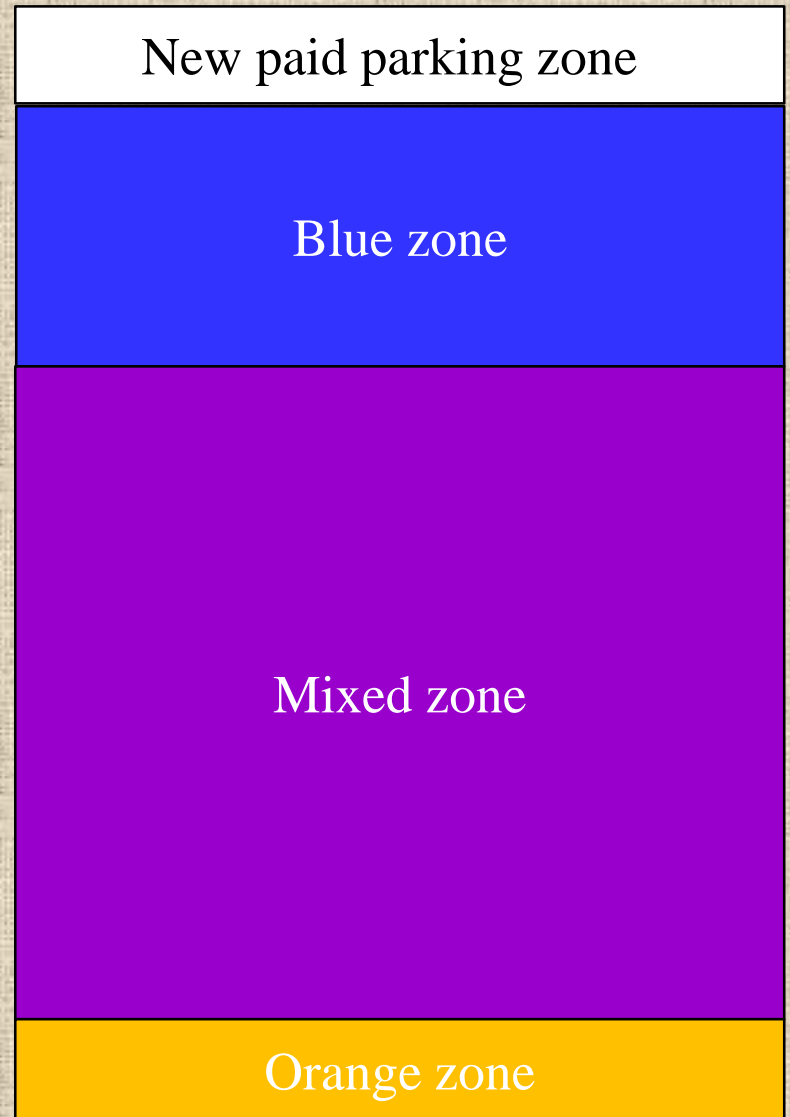
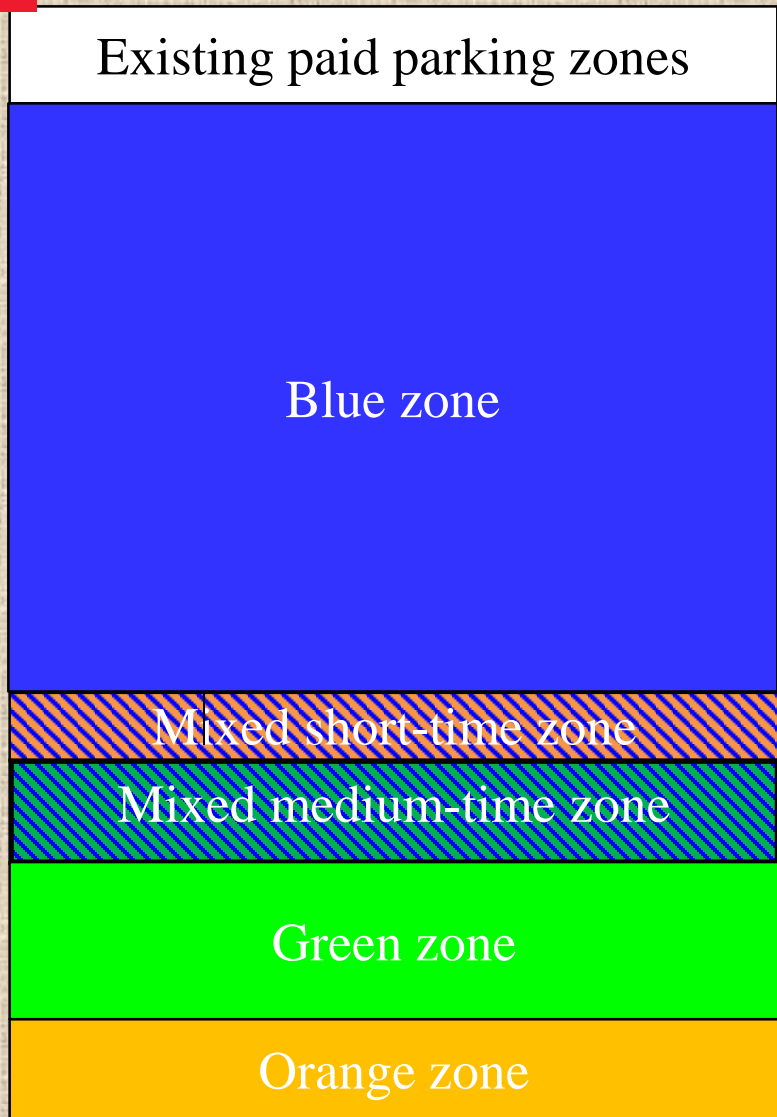

Basic scheme of the new system

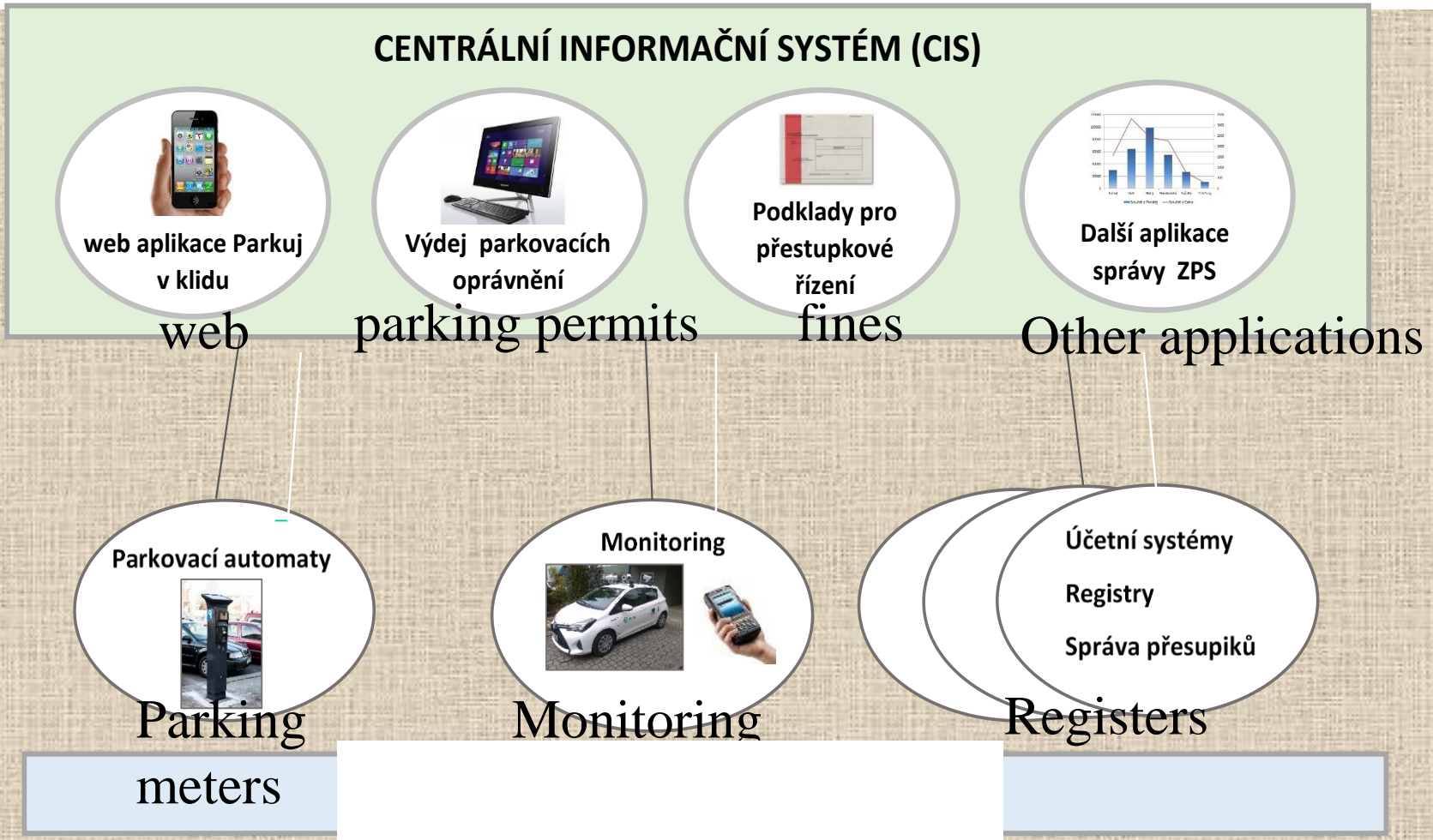

MONITORING

Central registry of parking payments

Central registry of monitoring data

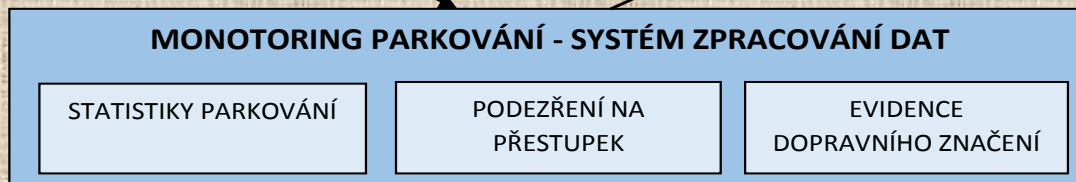

Aplikace mobilního sběru dat



Aplikace ručního sběru dat

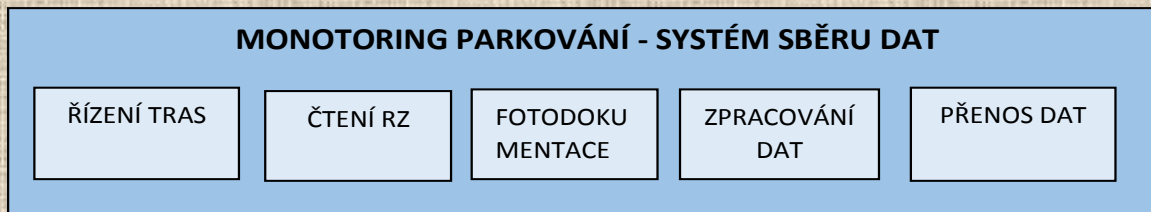

MONITORING



4 specialized cameras – 2 forward
+ 2 backward (collecting licence
plates)
2 monitoring cameras – right + left
(monitoring photos, traffic signs)



Control system:
Accurate determination of position
Launching systems by position
Route navigation

Illustration of route management at twice the data collection

- The drivers of both vehicles have information on time spacing on the navigation
 The dispatching center has a overview map to visualize the movement of vehicles

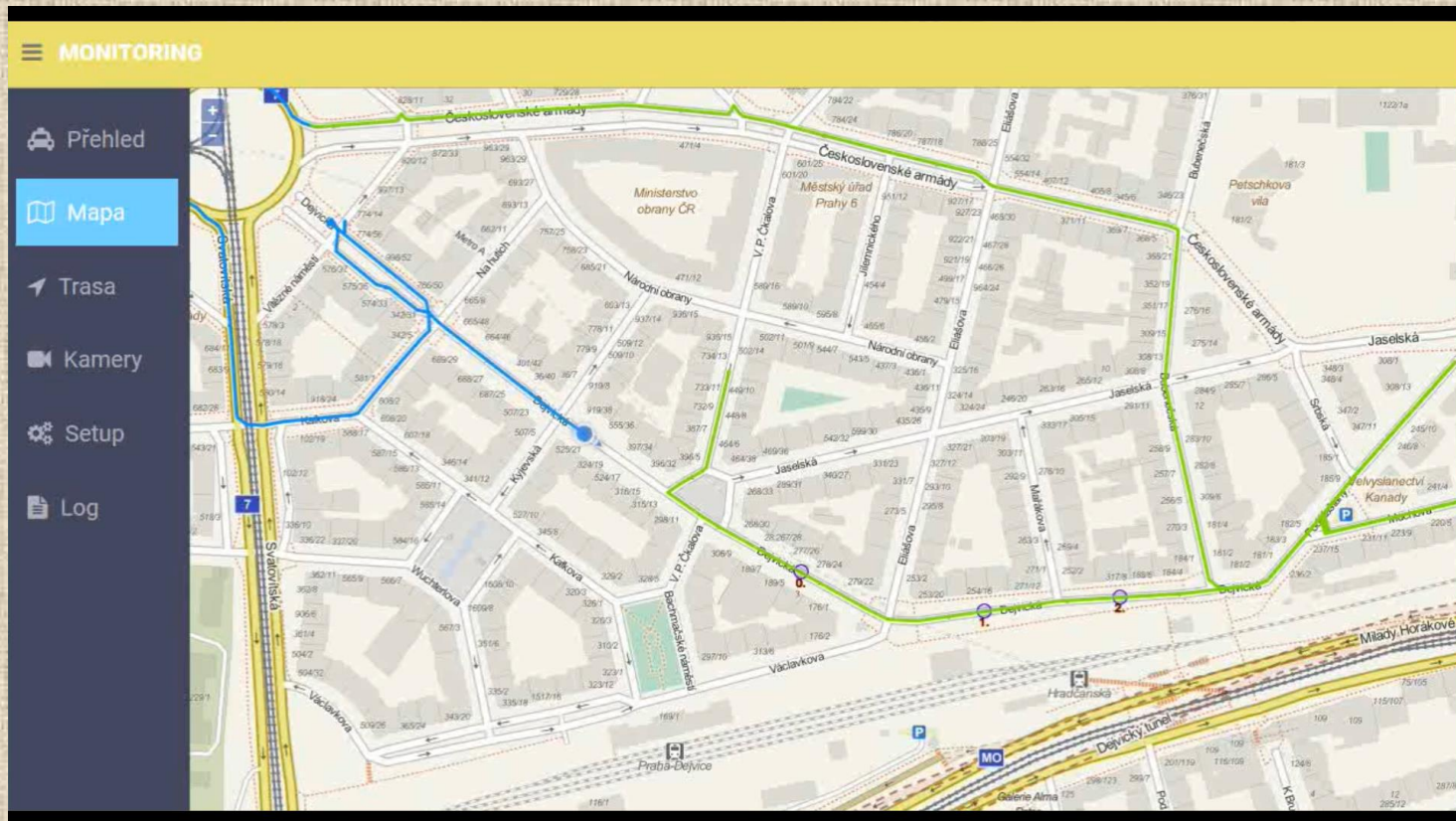

Activities of the vehicle

- Collecting data on parking vehicles
- The camera system makes a video recording to automatically search for and recognize the license plate and photographic record of the situation in the parking zone and the state of road signs
- Server placed in the car handles images - transfer to the vehicle registration number
- Transferring information about the registration number of the secured vehicle to the central information system (on-line query on the justification of the parking)
- The monitoring system does not retain the data on the legally parked, but deletes it immediately the result - statistics, basis for suspicion of offence

Activities of the vehicle

Varifying the suspicion of offence

- The vehicle sends a query for a legal parking - answer: licence number registered in the central information system as a paid = YES, as not payed = NO
- In the case of NO - it stores data constituting documents of the suspected offence (offence documentation package = licence plate photo + photo of the situation + traffic sign photo + data)
- If YES - all data will be deleted
- It stores suspicion packages 1x daily in a central information system (which it later passes on with the set method)
- The monitoring system does not keep or handle packages after passing them over to the CIS
- Result - packages of suspected offence transmitted to City Police

Use of profits

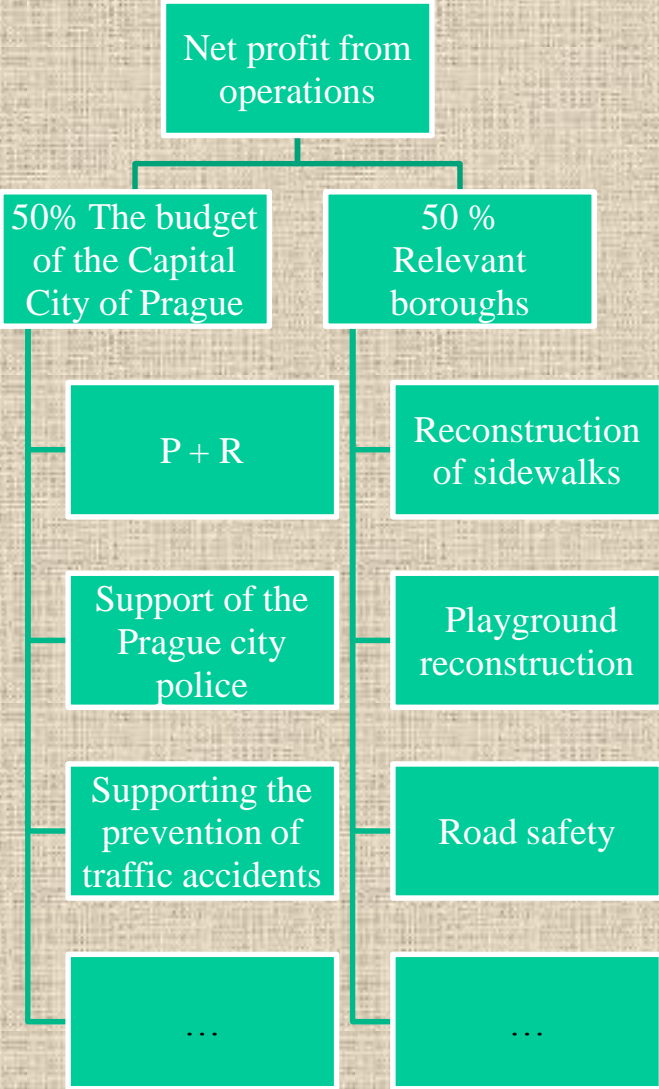

Thank you for your attention

Ing. Libor Šíma
City of Prague
libor.sima@praha.eu